

1. Safety Precautions

- The following is intended for the person responsible for installing or servicing the Solenoid Valve Controller. Before conducting installation or electrical work, be sure to carefully read these "Safety Precautions". Follow instructions exactly in all installation or electrical work.
 - The precautions given in this manual consist of specific "Warnings" and "Cautions". They provide important safety related information and are important for your safety, the safety of others, and troublefree operation of the system. Be sure to strictly observe all safety procedures. The labels and their meanings are as described below.
- Warning** This symbol refers to a hazard or unsafe procedure or practice which can result in severe personal injury or death.
- Caution** This symbol refers to a hazard or unsafe procedure or practice which can result in personal injury or product or property damage.
- Warning**
- Be sure to arrange installation at the dealer where the system was purchased or use a professional installer. Leaks, electric shock or fire may result if an inexperienced person performs any installation or wiring procedures incorrectly.
 - Be sure to turn off the power source circuit breaker of the unit before installation or wiring. High electrical voltages used in the unit may cause electric shock.
 - Only a qualified electrician should attempt to install this system, in accordance with the provisions of the Technical standards for Electrical Installations, local regulations for indoor wirings and these "Installation (Electric) and Service Instructions". Be sure to use a dedicated electrical circuit.
 - Insufficient electrical circuit capacity may cause electric shock or fire.
 - Use the specified cables (type and wiring diameter) for the electrical connections, and securely connect the cables. Run and fasten the cables securely so that external forces or pressure placed on the cables will not be transmitted to the connection terminals. Overheating or fire may result if connections or attachments are not secure.
 - Install in a location that is fully strong enough to support the weight of the unit. If it is not strong enough, the unit may fall, resulting in injury.
 - Ventilate the work area if cooling gas leaks during installation. Poisonous gas can result if cooling gas comes into contact with fire.
 - After installation, check to be sure that there are no gas leaks.
 - Poisonous gas can result if cooling gas leaks into the room and comes into contact with a fan heater, stove, range, or other source of fire.
- Caution**
- Do not install in a location subject to leakage of flammable gasses. Fire can result if gas builds up around the unit.

2. Supplied Parts

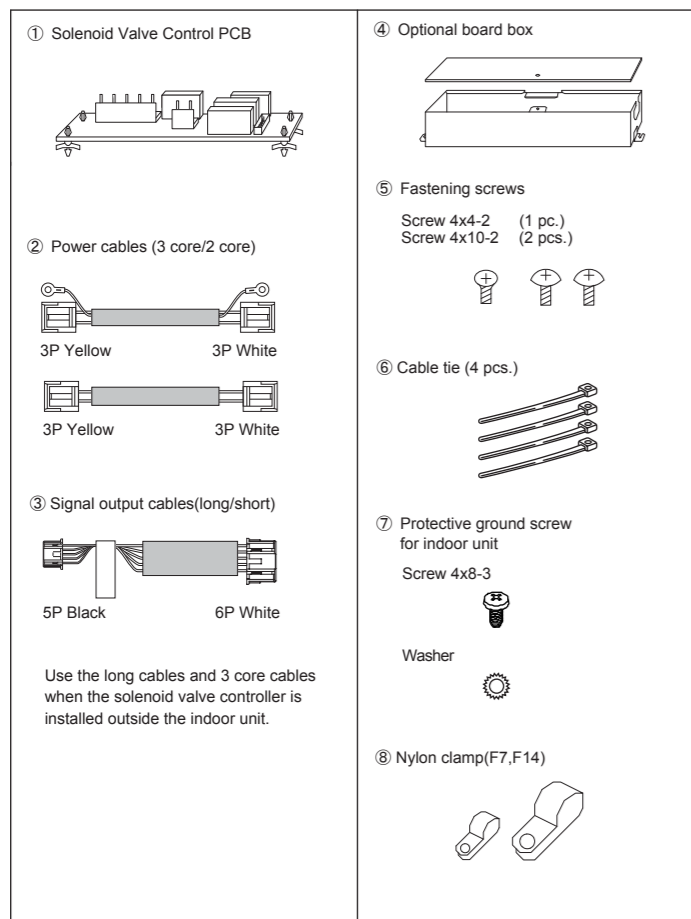

3. Wiring Diagram

- Connect to the indoor control PCB with power cable(2 core/3 core) (Supplied part ②) and Signal output cable (Supplied part ③)
- The connected solenoid valve is a solenoid valve kit, or a gas pipe valve kit.

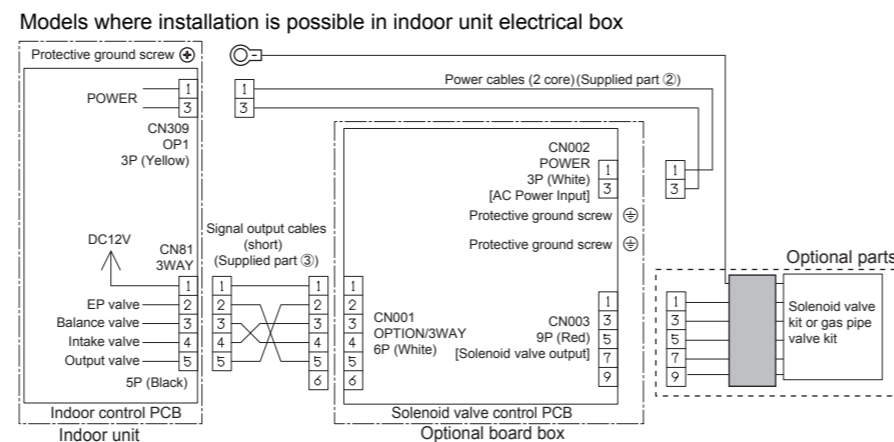
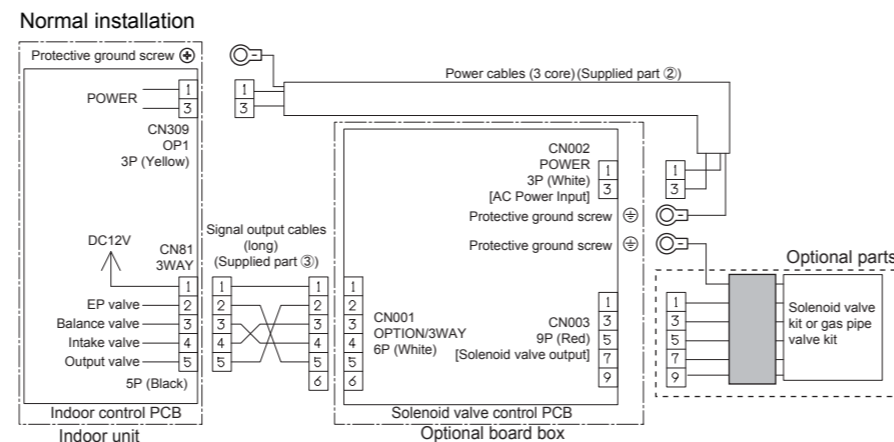

4. Installation Procedures

※ Note: See the reverse side for procedures for installation on various indoor units.

Models where installation is possible in indoor unit electrical box

1. Install the spacers for the solenoid valve control PCB in the electrical box.
2. Wire according to the following procedure.
 - Connect the 3P white connector of power cable(2 core) (Supplied part ②) to POWER (CN002) on the solenoid valve control PCB.
 - Connect the 3P yellow connector to OP1 (CN309) on the indoor control PCB.
 - Connect the 6P white connector of Signal output cable (the short cable) (Supplied part ③) to OPTION/3WAY (CN001) on the solenoid valve control PCB.
 - Connect the 5P black connector to 3WAY (CN81) on the indoor control PCB.
 - Connect the connector from the solenoid valve kit or gas pipe valve kit (9P red) to the 9P red connector (CN003) on the solenoid valve control PCB.
 - Connect the ground wire of the solenoid valve kit or gas pipe valve kit to the indoor unit using the screw and washer (supplied part ⑦).
 - * For the connecting location, refer to the indoor unit installation instructions.
3. When you have finished wiring work, check to be sure that there are no nipped portions in the wiring.

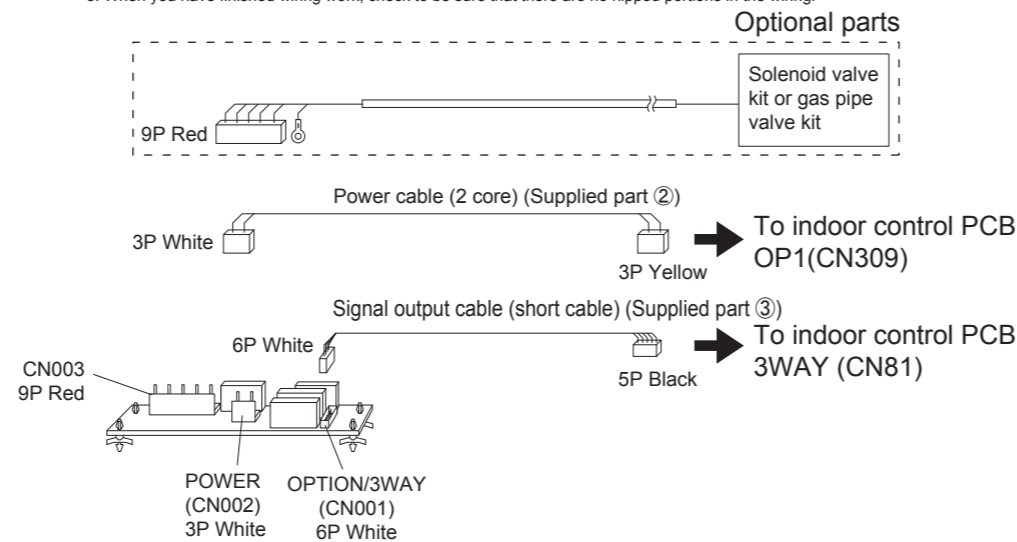

Models without space inside electrical box

1. Install the solenoid valve control PCB in the optional board box with the following procedure.
 - Install the board spacers in the holes in the base of the optional board box. Note: When you do so, be careful of the direction of the solenoid valve control PCB(see following figure).
 - Attach the optional board box to the unit with the supplied screws(4x10).
 2. Wire according to the following procedure.
 - Connect the 3P yellow connector of power cable (Supplied part ②) to OP1 (CN309) on the indoor control PCB.
 - Connect the 5P black connector of signal output cable (Supplied part ③) to 3WAY (CN81) on the indoor control PCB.
 - Connect the ground wire of the power cables (3 core) to the indoor unit using the screw and washer (supplied part ⑦).
 - * For the connecting location, refer to the indoor unit installation instructions.
 - * When you use the power cables (2 core) for installing inside electrical box, ground connection is unnecessary.
 - Connect the ground wires of the power cables and solenoid valve kit or gas pipe valve kit to the optional board box.
 - * When you use the power cables (2 core), only connect the ground wire of the solenoid valve kit or gas pipe valve kit.
 - Connect the 3P white connector of power cable(Supplied part ②) to POWER(CN002) on the solenoid valve control PCB.
 - Connect the 6P white connector of signal output cable(Supplied part ③) to OPTION/3WAY(CN001) on the solenoid valve control PCB.
 - Connect the connector from the solenoid valve kit or gas pipe valve kit (9P red) to the 9P red connector (CN003) on the solenoid valve control PCB.
 - Fasten the wires to the optional board box with the cable ties (supplied part ⑥)
 3. When you have finished wiring work, secure the cover of the optional board box with the supplied screw (4x4)
- Note: When you do so, check to be sure that there are no nipped portions in the wiring.

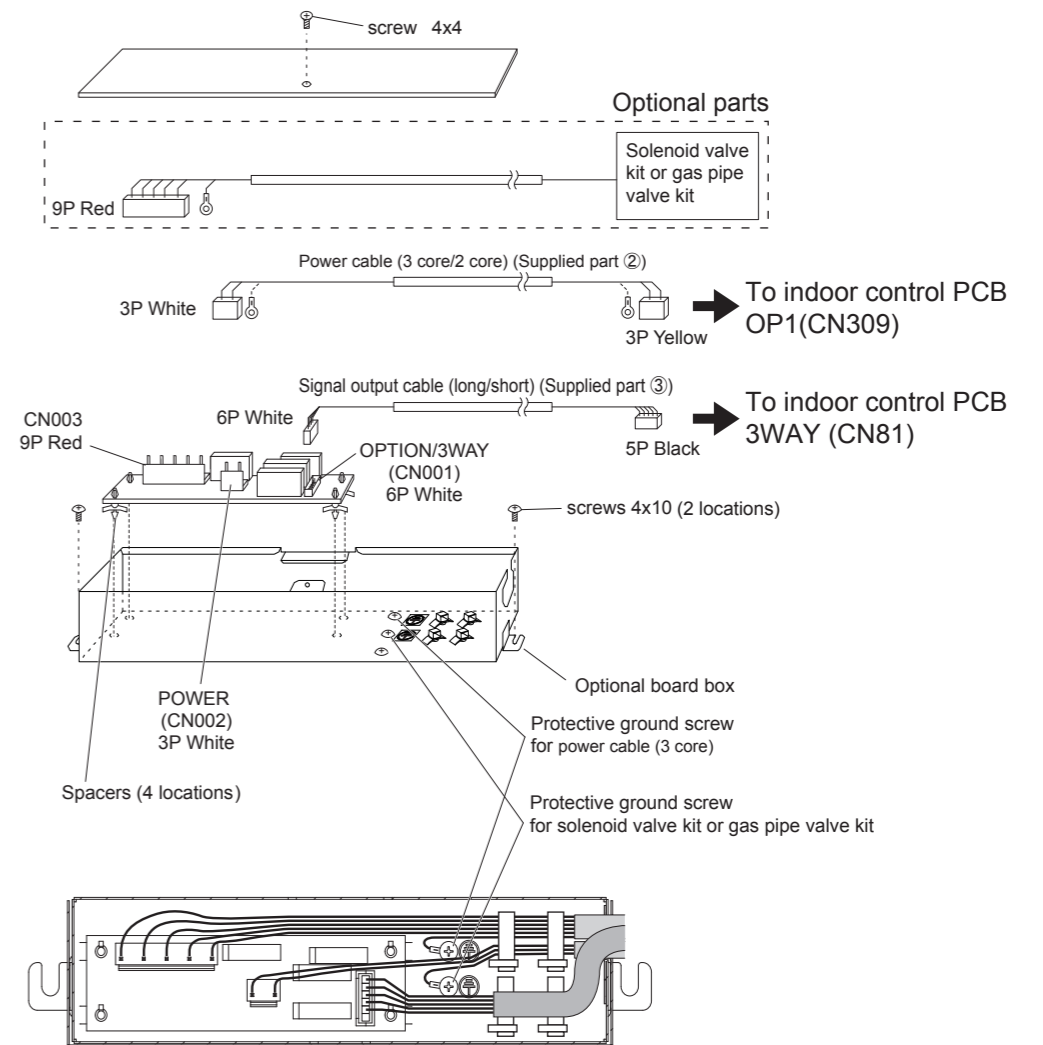
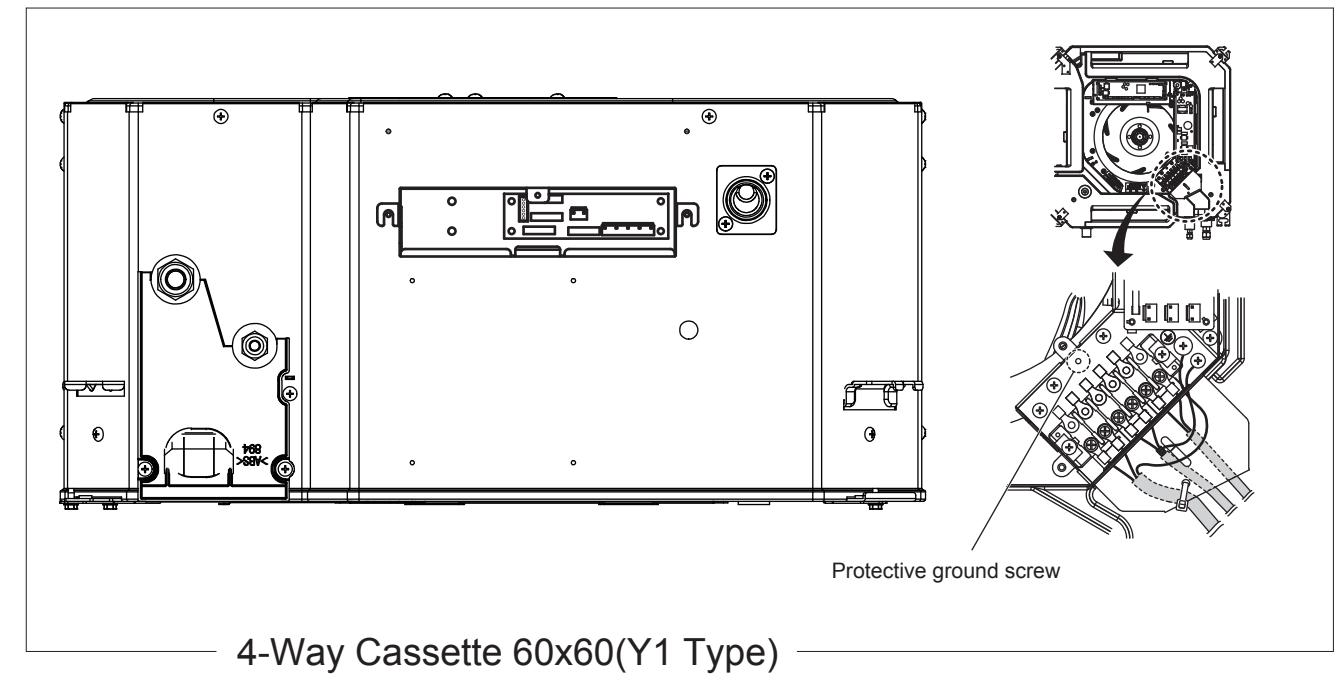
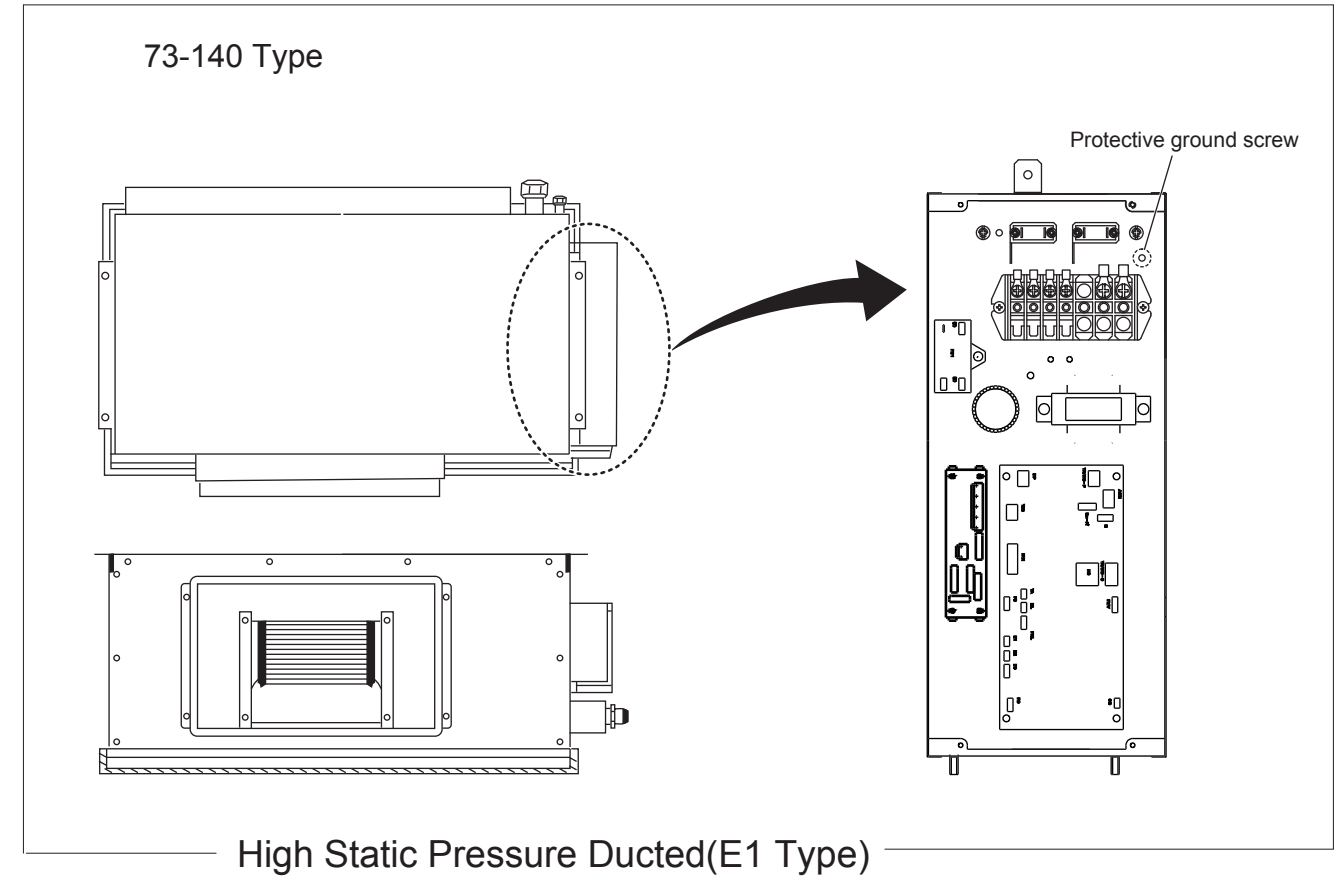
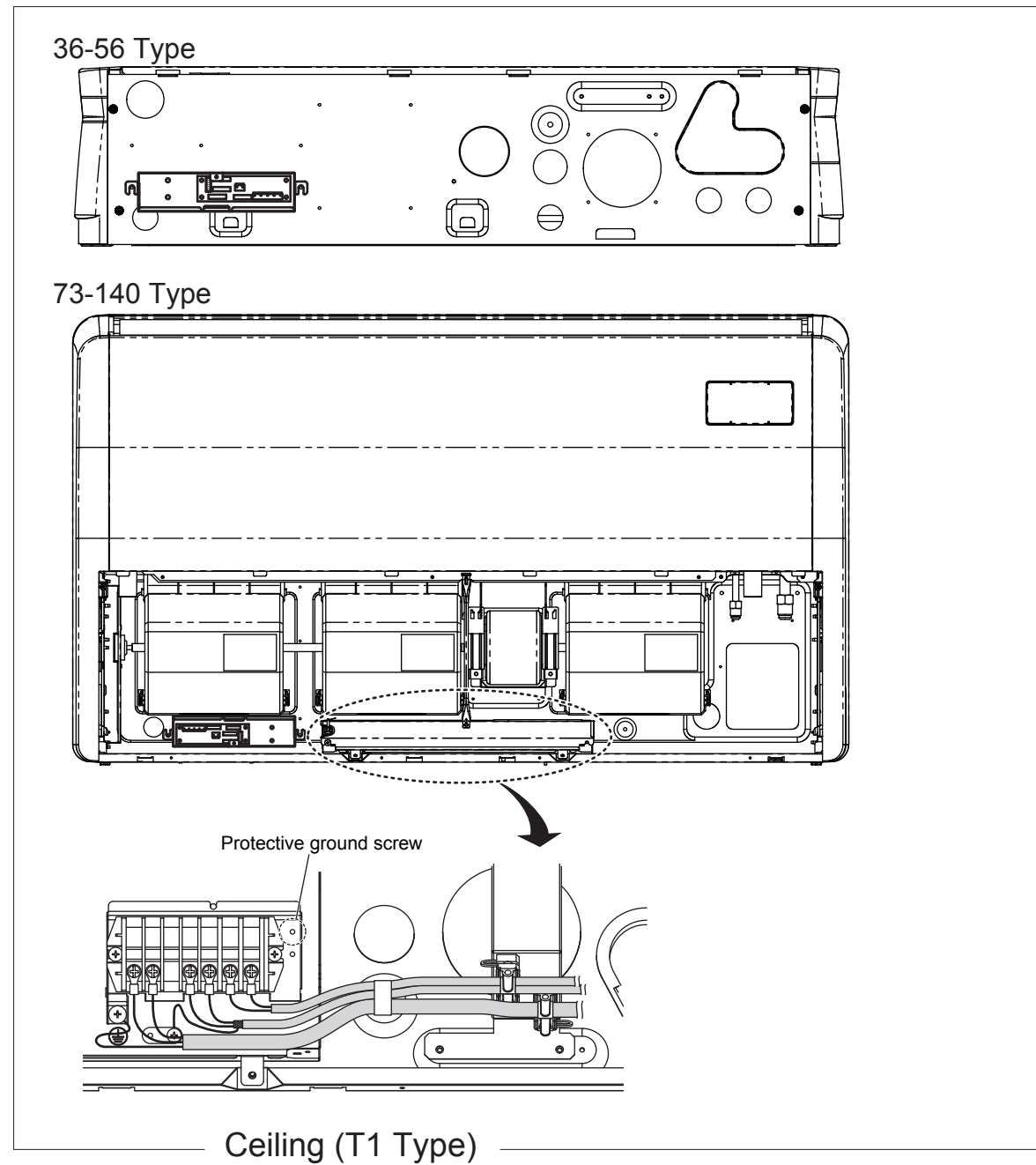
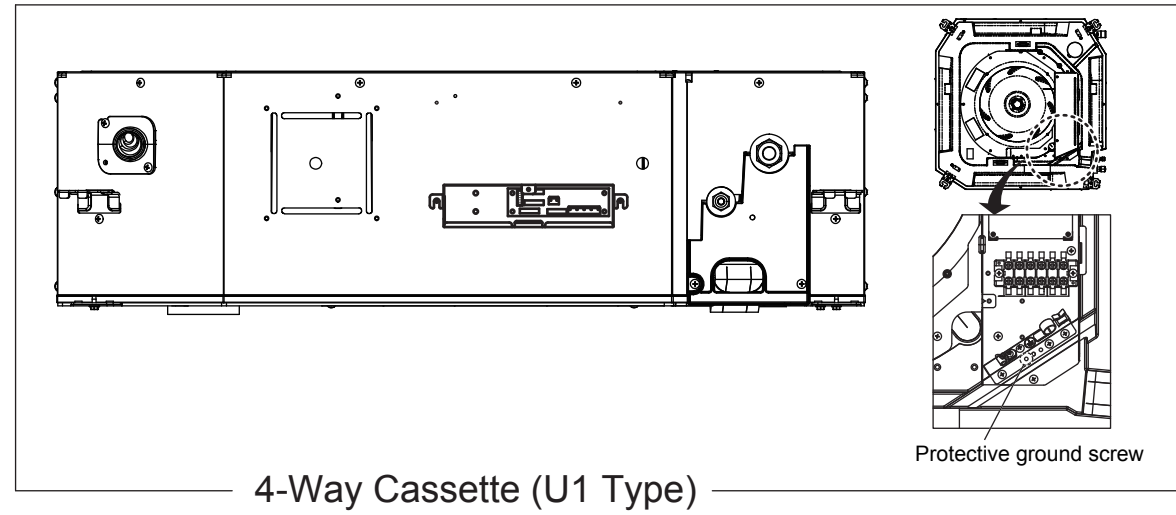
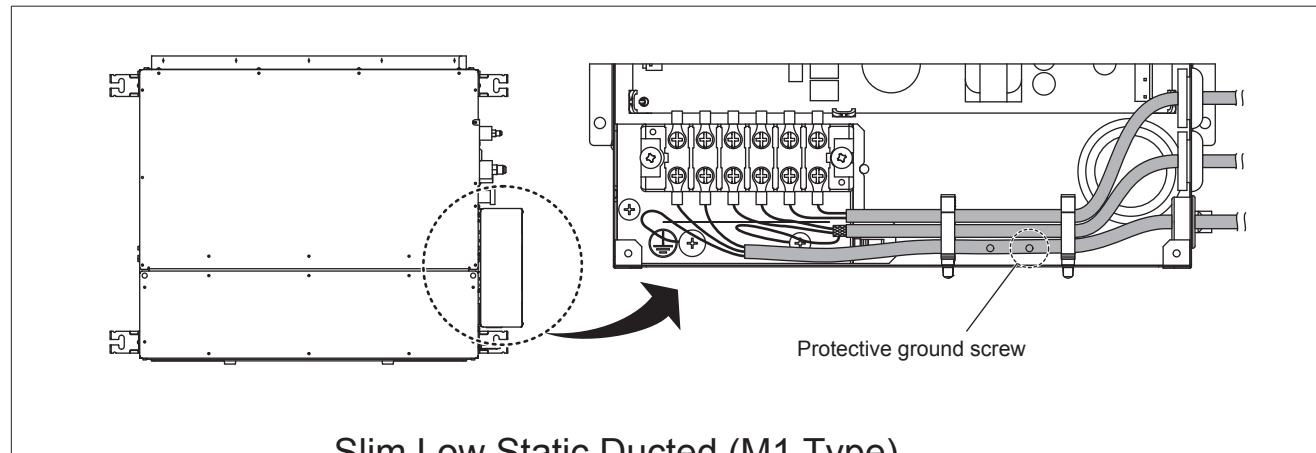
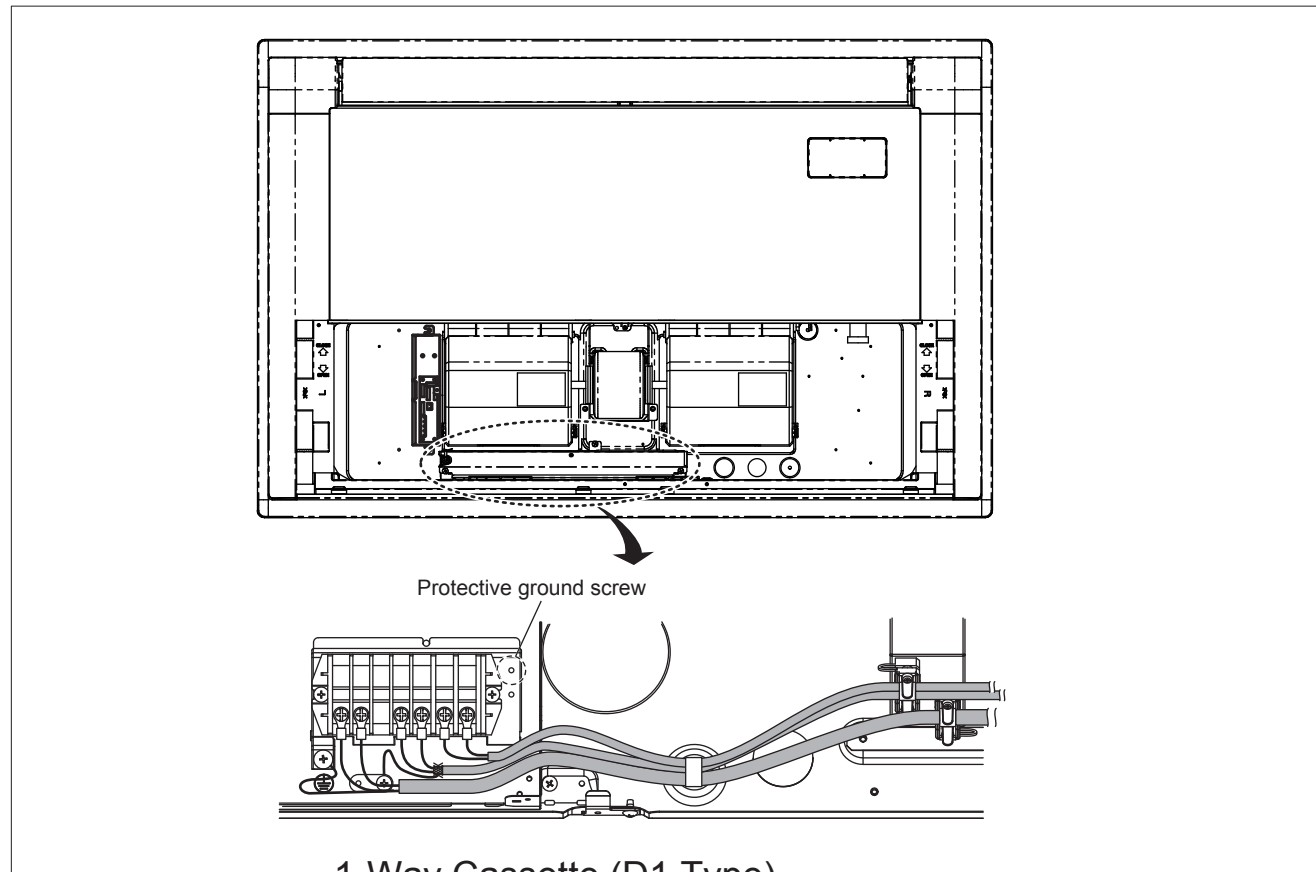

Figure of installation to each Indoor unit





Slim Low Static Ducted (M1 Type)



1-Way Cassette (D1 Type)

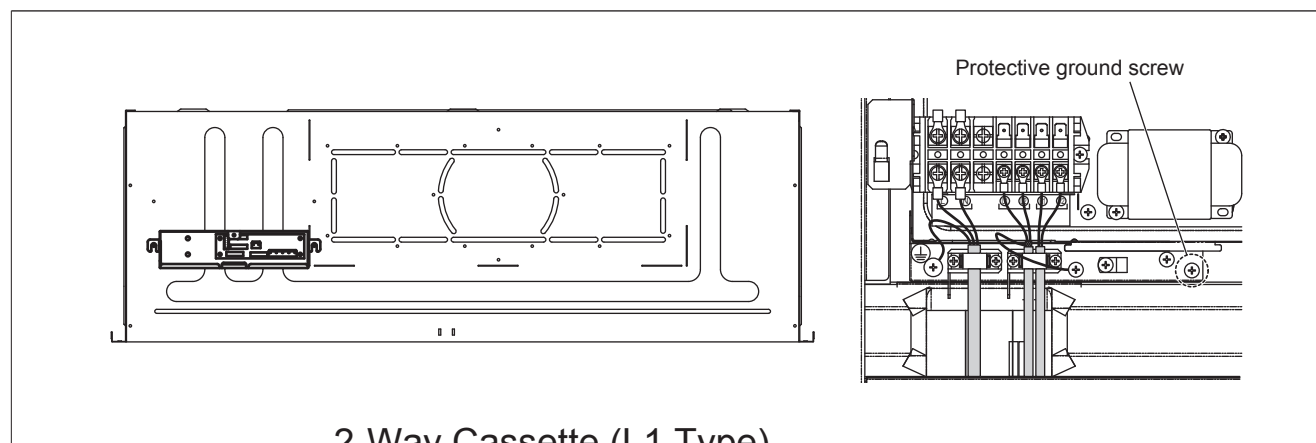

2-Way Cassette (L1 Type)

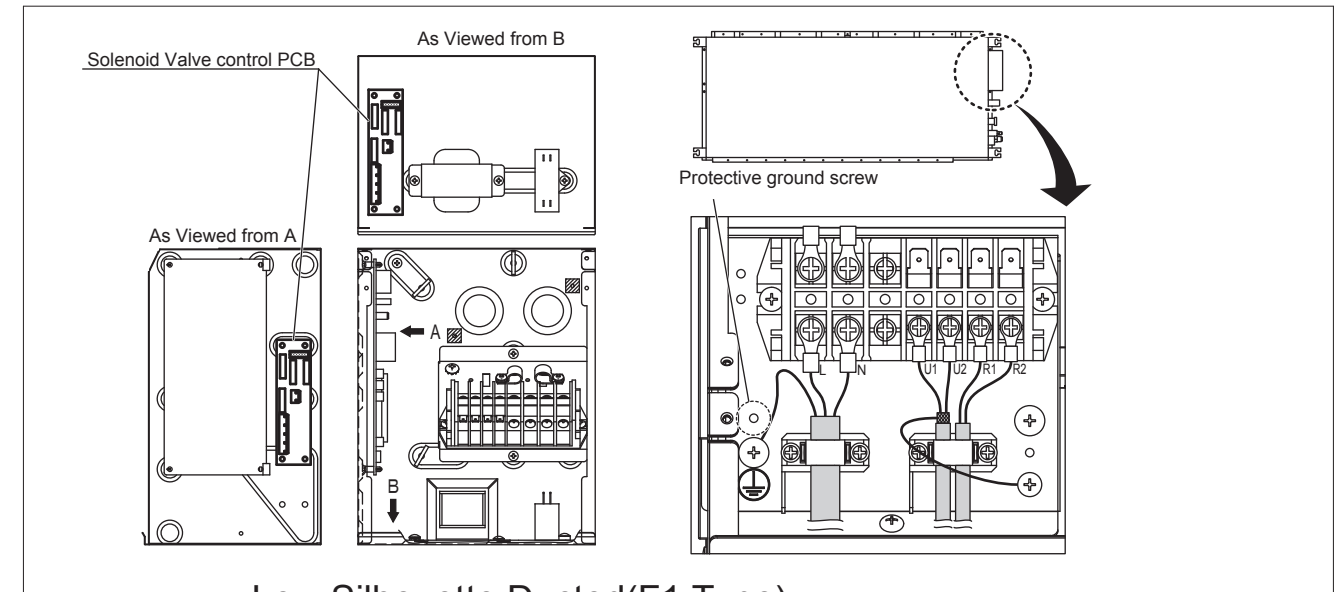

Low Silhouette Ducted (F1 Type)

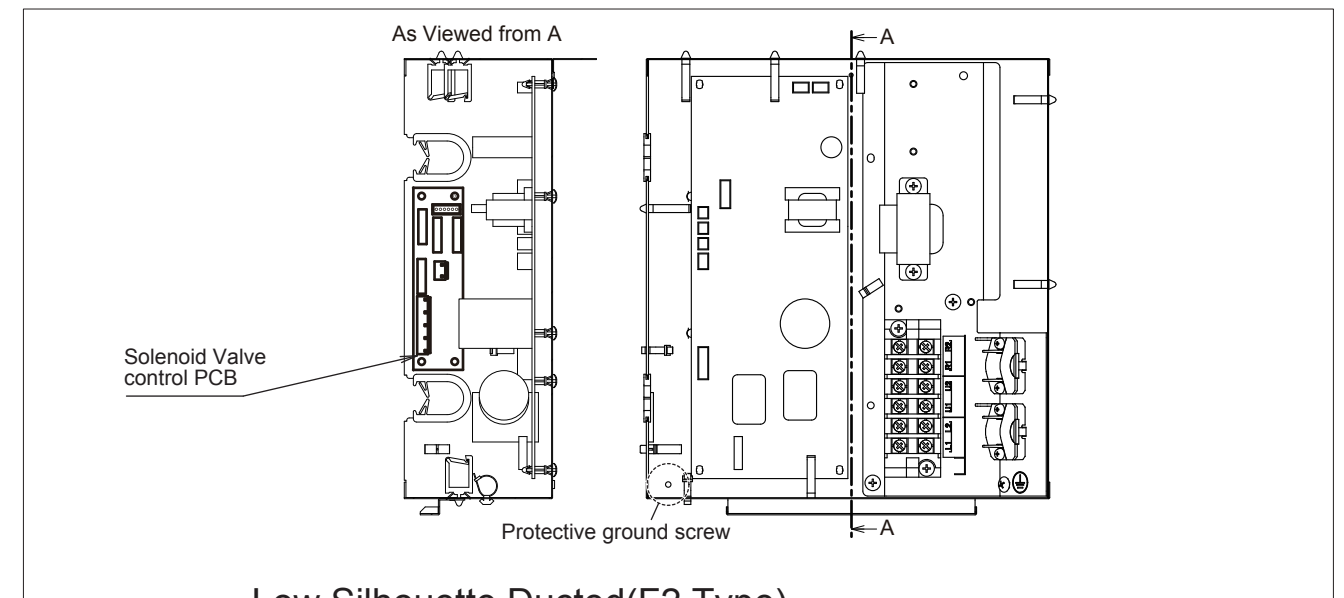

Low Silhouette Ducted (F2 Type)

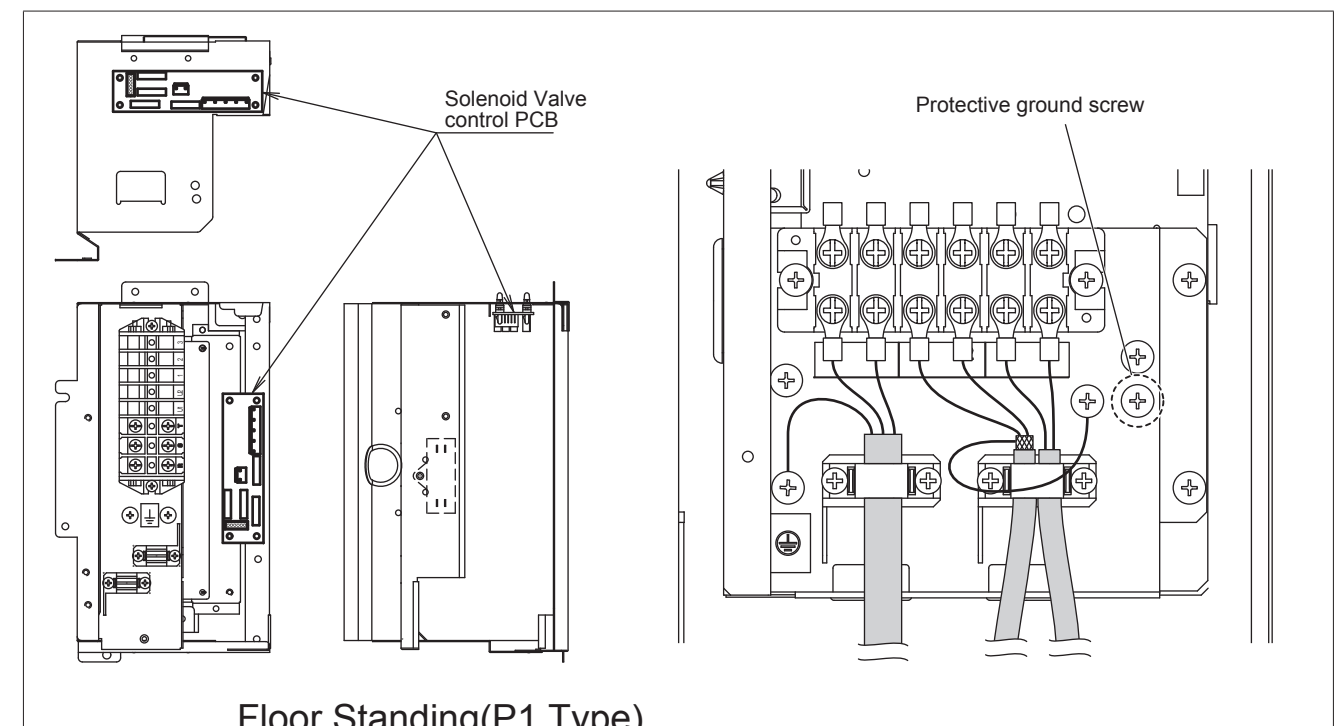

Floor Standing (P1 Type)
Concealed Floor Standing (R1 Type)