

11. Floor Standing (Type P1)

11-3. Dimensional Data

Indoor unit: S-22MP1E5, S-28MP1E5, S-36MP1E5, S-45MP1E5, S-56MP1E5, S-71MP1E5

Unit: mm

Indoor unit	A	B	C	Liquid tube	Gas tube
S-22MP1E5, S-28MP1E5, S-36MP1E5	1,065	665	632	ø6.35	ø12.7
S-45MP1E5	1380	980	947		
S-56MP1E5					
S-71MP1E5				ø9.52	ø15.88

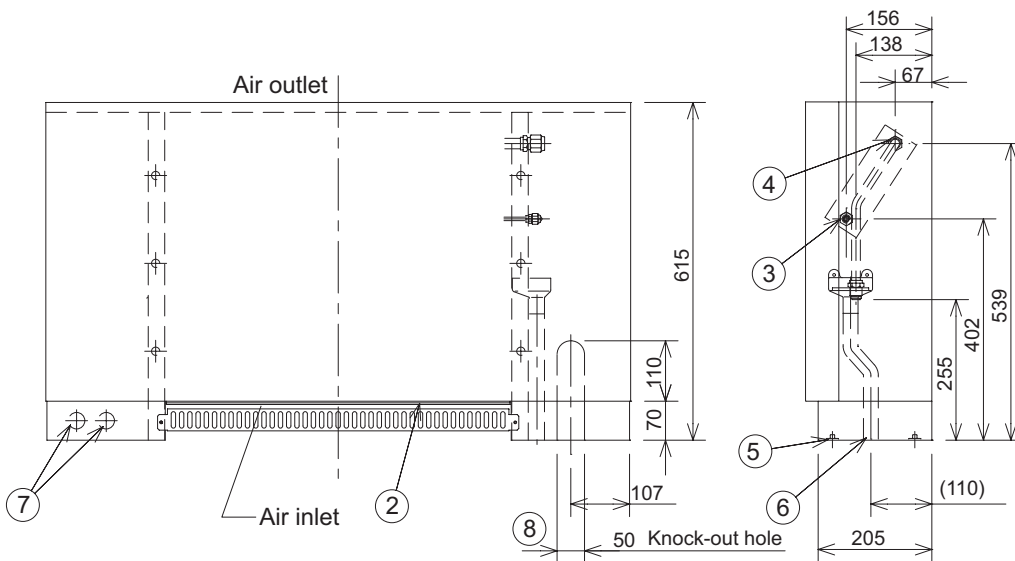
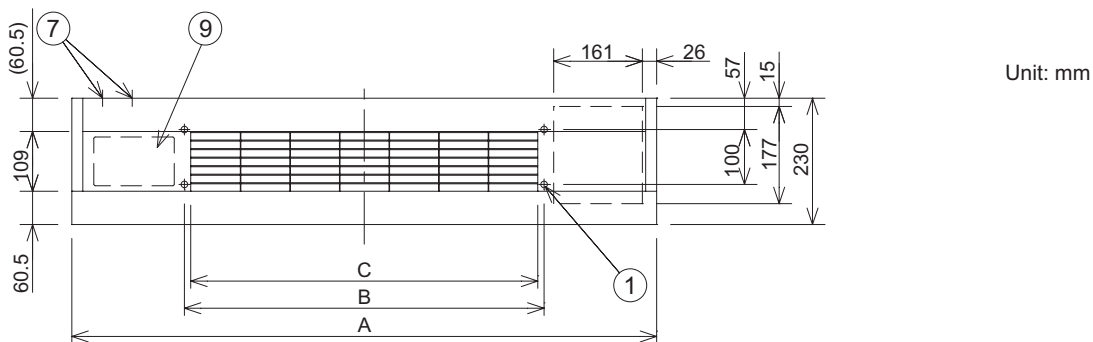

- ① 4-ø12 hole (For fastening the indoor unit to the floor with screws.)
- ② Air filter
- ③ Refrigerant connection outlet (liquid tube)
- ④ Refrigerant connection outlet (gas tube)
- ⑤ Level adjusting bolt
- ⑥ Drain outlet (20 A)
- ⑦ Power cord outlet (downward, rear)
- ⑧ Refrigerant tubing outlet (downward, rear)
- ⑨ Location for mounting the remote controller (Remote controller can be attached within the room.)