

12. Concealed Floor Standing (Type R1)

12-3. Dimensional Data

Indoor unit: S-22MR1E5, S-28MR1E5, S-36MR1E5, S-45MR1E5, S-56MR1E5, S-71MR1E5

unit: mm

Indoor unit	A	B	C	D	E	F	Liquid tube	Gas tube
S-22MR1E5, S-28MR1E5, S-36MR1E5	904	692	672	665	500	86	ø6.35	ø12.7
S-45MR1E5	1219	1007	1002	980	900	51		
S-56MR1E5							ø9.52	ø15.88
S-71MR1E5								

Unit: mm

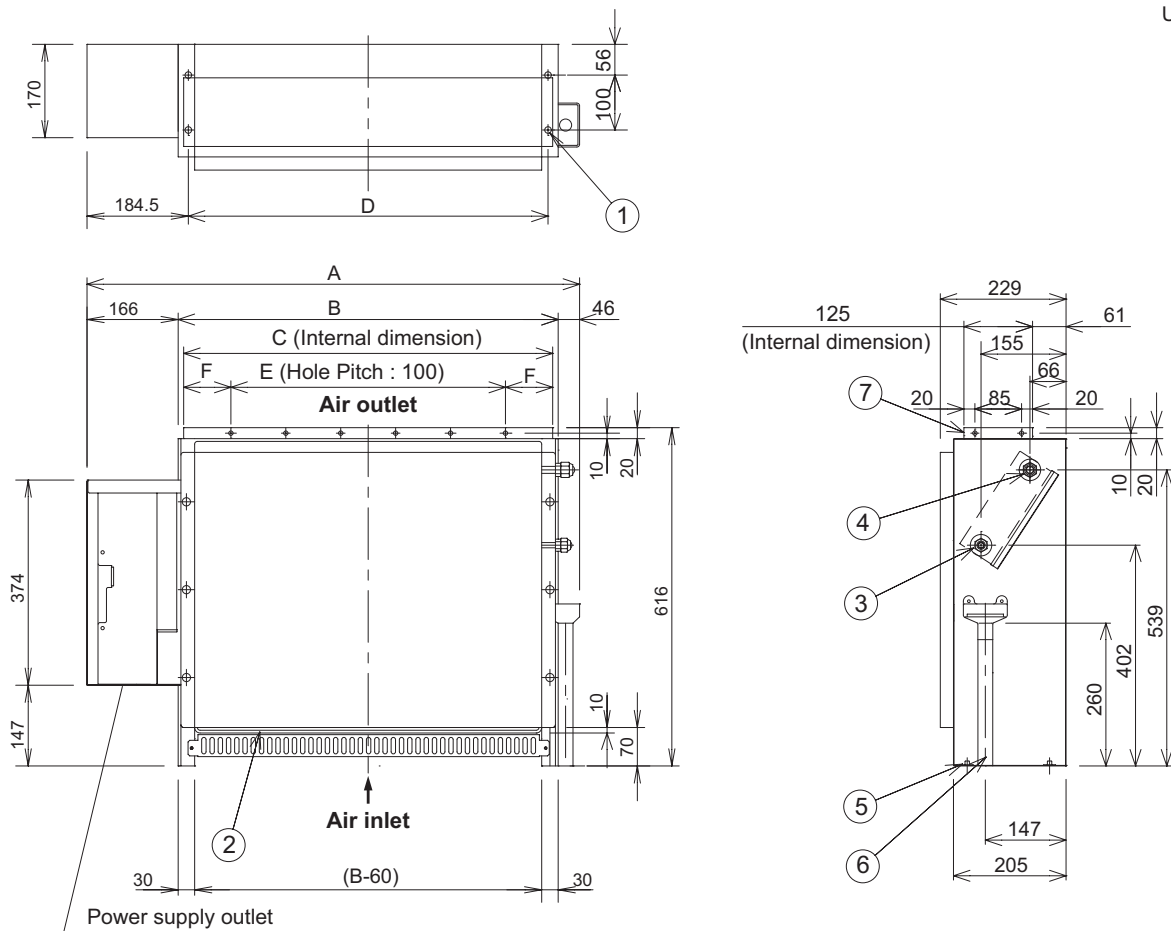

- ① 4-ø12 hole (For fastening the indoor unit to the floor with screws.)
- ② Air filter
- ③ Refrigerant connection outlet (liquid tube)
- ④ Refrigerant connection outlet (gas tube)
- ⑤ Level adjusting bolt
- ⑥ Drain outlet (20 A)
- ⑦ Flange for the air-outlet duct

NOTE

Make an opening in the housing of the unit so that maintenance service can be performed on the electric component box, air filter, refrigerant tubing connection, and drain pipe.