

1. Air-to-Water Heatpump (Type W1)

1-3. Dimensional Data

S-80MW1E5 / S-125MW1E5

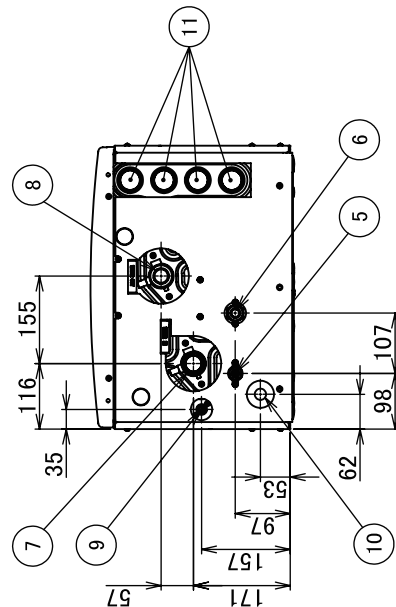
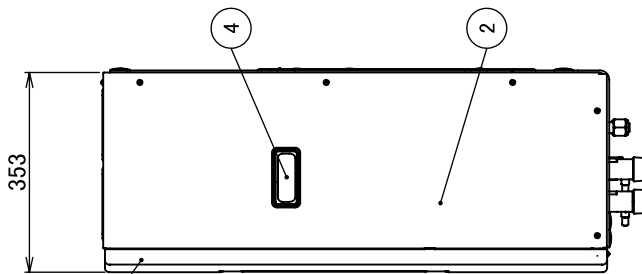
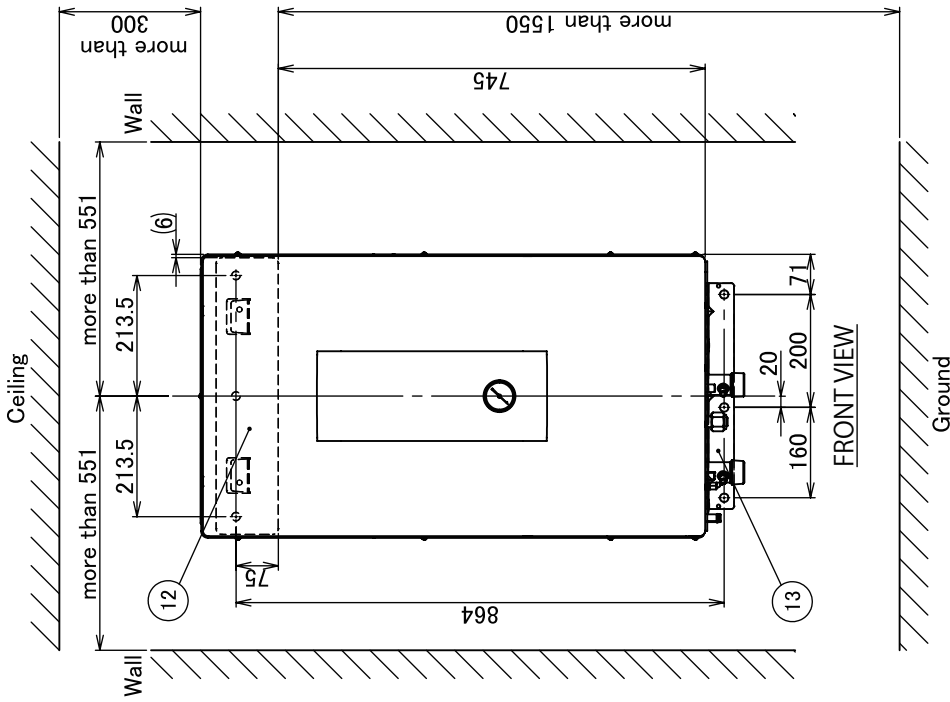

①	Cabinet front plate	⑧	Water tubing (outlet) use Rp 1 1/4" nut
②	Cabinet	⑨	Drain hose connection port (outer dia. φ15)
③	Pressure gauge	⑩	Attachment hole for drain elbow (accessory)
④	Handle (both side)	⑪	Bushing (cable port)
⑤	Refrigerant tubing (liquid tube) φ 9.52 (flared)	⑫	Installation plate (accessory)
⑥	Refrigerant tubing (gas tube) φ 15.88 (flared)	⑬	Installation plate (accessory)
⑦	Water tubing (inlet) use Rp 1 1/4" nut		

(Unit : mm)