

1. Outdoor Unit

1-2. Dimensional Data U-10LE1E8

Unit: mm

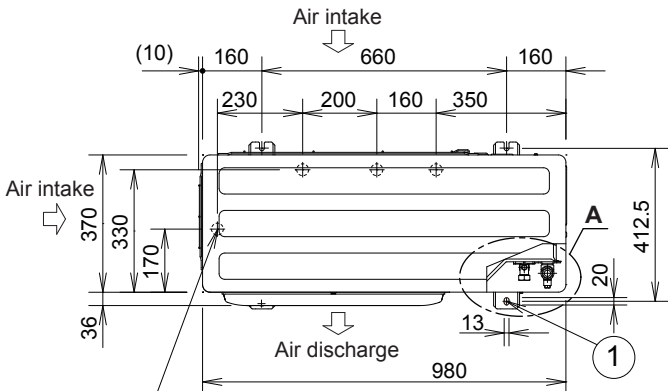

4 × ϕ 32 holes (holes for drain)
When using a drain pipe, install the drain socket (field supply) onto the drain port. Seal the other drain port with the rubber cap.

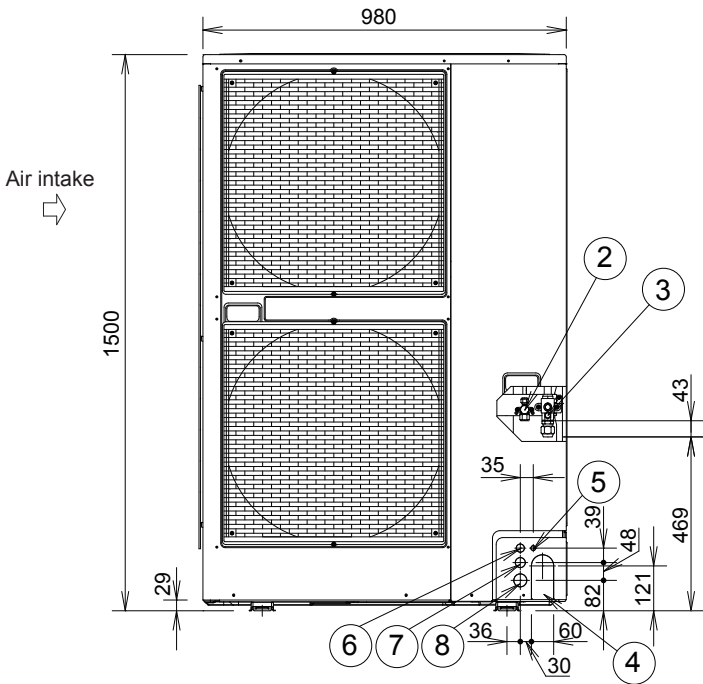

①	Mounting hole (4-R6.5), anchor bolt : M10
②	Refrigerant tubing (liquid tube), flared connection (ϕ 9.52)
③	Refrigerant tubing (gas tube), flared connection (ϕ 19.05)
④	Refrigerant tubing port
⑤	Electrical wiring port (ϕ 13)
⑥	Electrical wiring port (ϕ 22)
⑦	Electrical wiring port (ϕ 27)
⑧	Electrical wiring port (ϕ 35)

The tubing of the gas main has a diameter of ϕ 22.22, but the connection to the service valve of the outdoor unit has a diameter of ϕ 19.05, so a flare has to be used. Consequently, be sure to use the enclosed joint tube B and joint tube A in making connections (braze).

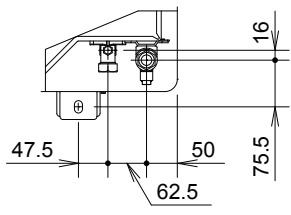
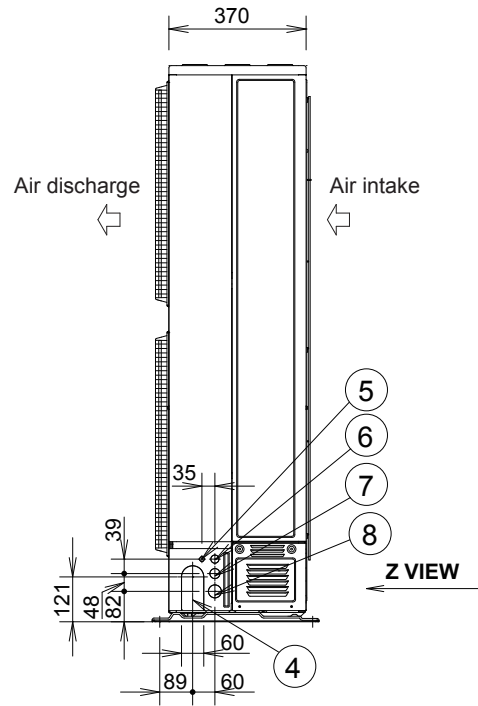

A VIEW

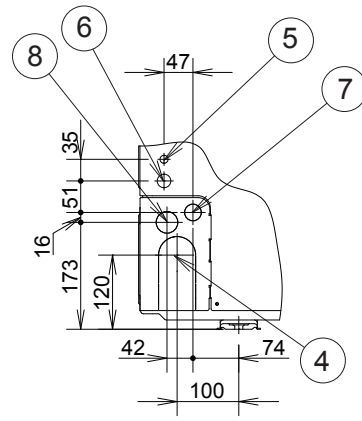

Z VIEW