

1. Outdoor Unit

1-2. Dimensional Data

U-4LE2E5, U-5LE2E5, U-6LE2E5
 U-4LE2E8, U-5LE2E8, U-6LE2E8

Unit: mm

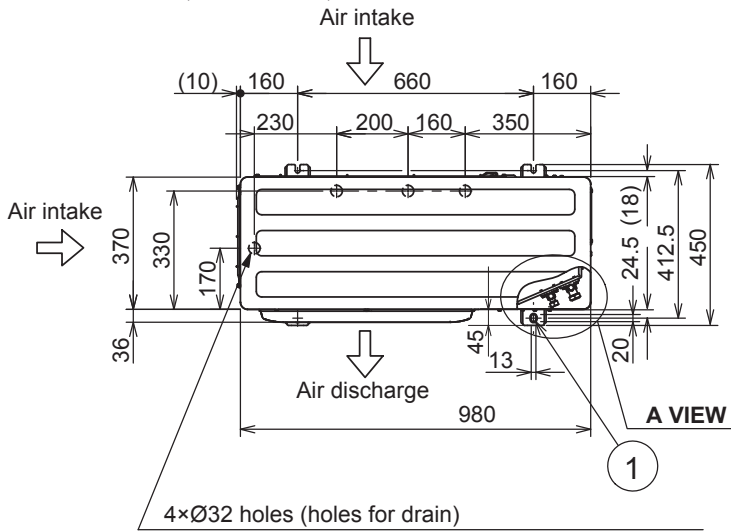

| | |
|---|---|
| ① | Mounting hole (4-R6.5), anchor bolt : M10 |
| ② | Refrigerant tubing (liquid tube), flared connection (Ø9.52) |
| ③ | Refrigerant tubing (gas tube), flared connection (Ø15.88) |
| ④ | Refrigerant tubing port |
| ⑤ | Electrical wiring port (Ø13) |
| ⑥ | Electrical wiring port (Ø22) |
| ⑦ | Electrical wiring port (Ø27) |
| ⑧ | Electrical wiring port (Ø35) |

When using a drain pipe, install the drain socket (field supply) on to the drain port. Seal the other drain port with the rubber cap.

4

