

# 1. Outdoor Unit

## 1-2. Dimensional Data U-8LZ2E8

Unit: mm

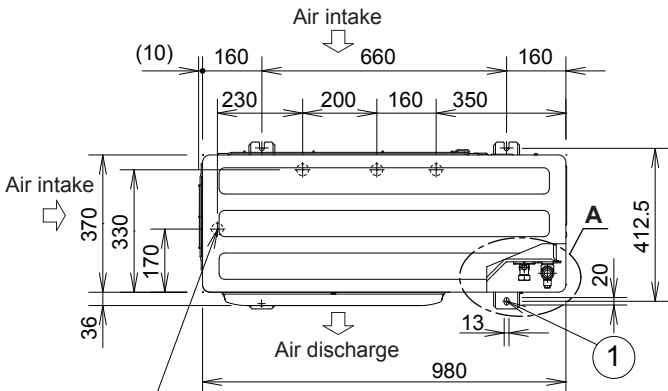

4 ×  $\phi$  32 holes (holes for drain)  
When using a drain pipe, install the drain socket (field supply) onto the drain port. Seal the other drain port with the rubber cap.

①	Mounting hole (4-R6.5), anchor bolt : M10
②	Refrigerant tubing (liquid tube), flared connection ( $\phi$ 9.52)
③	Refrigerant tubing (gas tube), flared connection ( $\phi$ 19.05)
④	Refrigerant tubing port
⑤	Electrical wiring port ( $\phi$ 13)
⑥	Electrical wiring port ( $\phi$ 22)
⑦	Electrical wiring port ( $\phi$ 27)
⑧	Electrical wiring port ( $\phi$ 35)

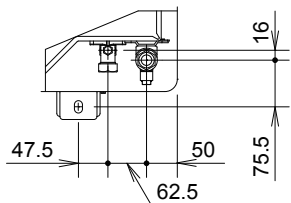
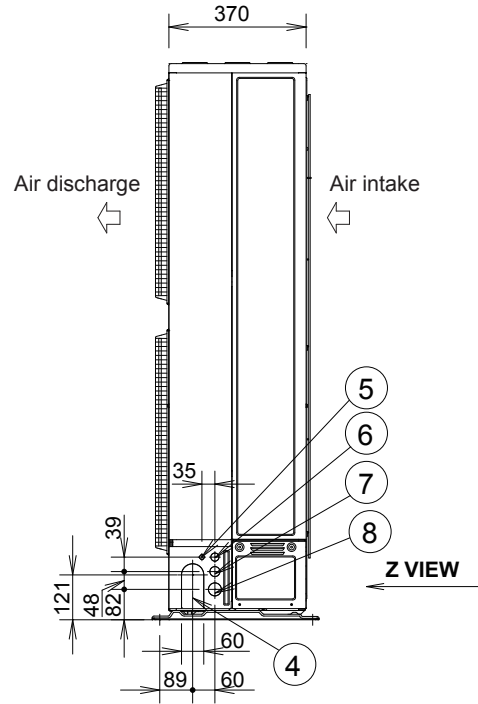
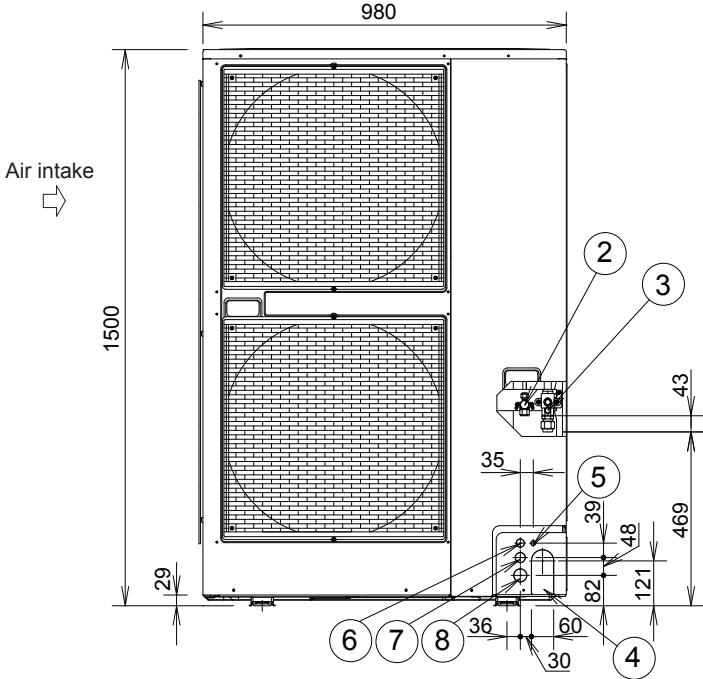

**A VIEW**

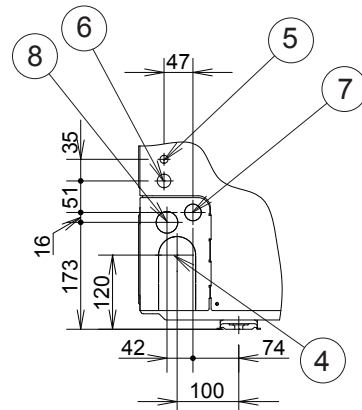

**Z VIEW**