

6. Dimensions

6.1 Indoor Unit

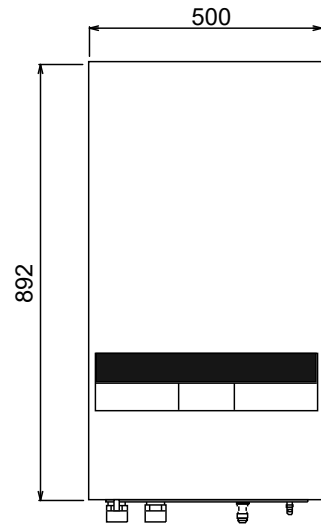

FRONT VIEW

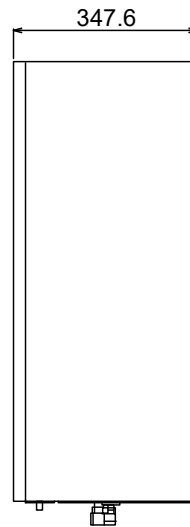

SIDE VIEW

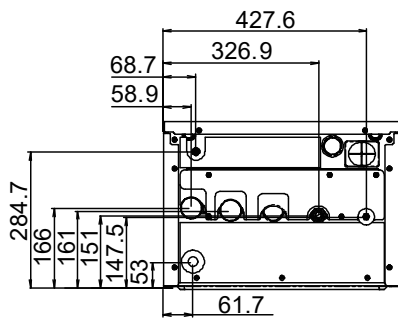

BOTTOM VIEW

Pipe Position Diagram

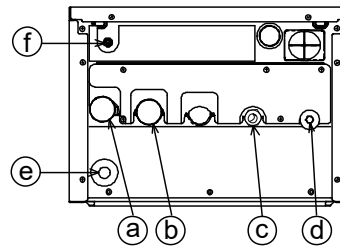

Letter	Pipe Description	Connection Size	
		WH-SDC**	WH-SXC**
Ⓐ	Water inlet	R 1¼"	R 1¼"
Ⓑ	Water outlet	R 1¼"	R 1¼"
Ⓒ	Refrigerant gas	7/8-14UNF	3/4-16UNF
Ⓓ	Refrigerant liquid	7/16-20UNF	7/16-20UNF
Ⓔ	Drain water hole	-	-
Ⓜ	Pressure relief valve drainage	3/8"	3/8"

Unit: mm

6.2 Outdoor Unit

6.2.1 WH-UDZ03KE5

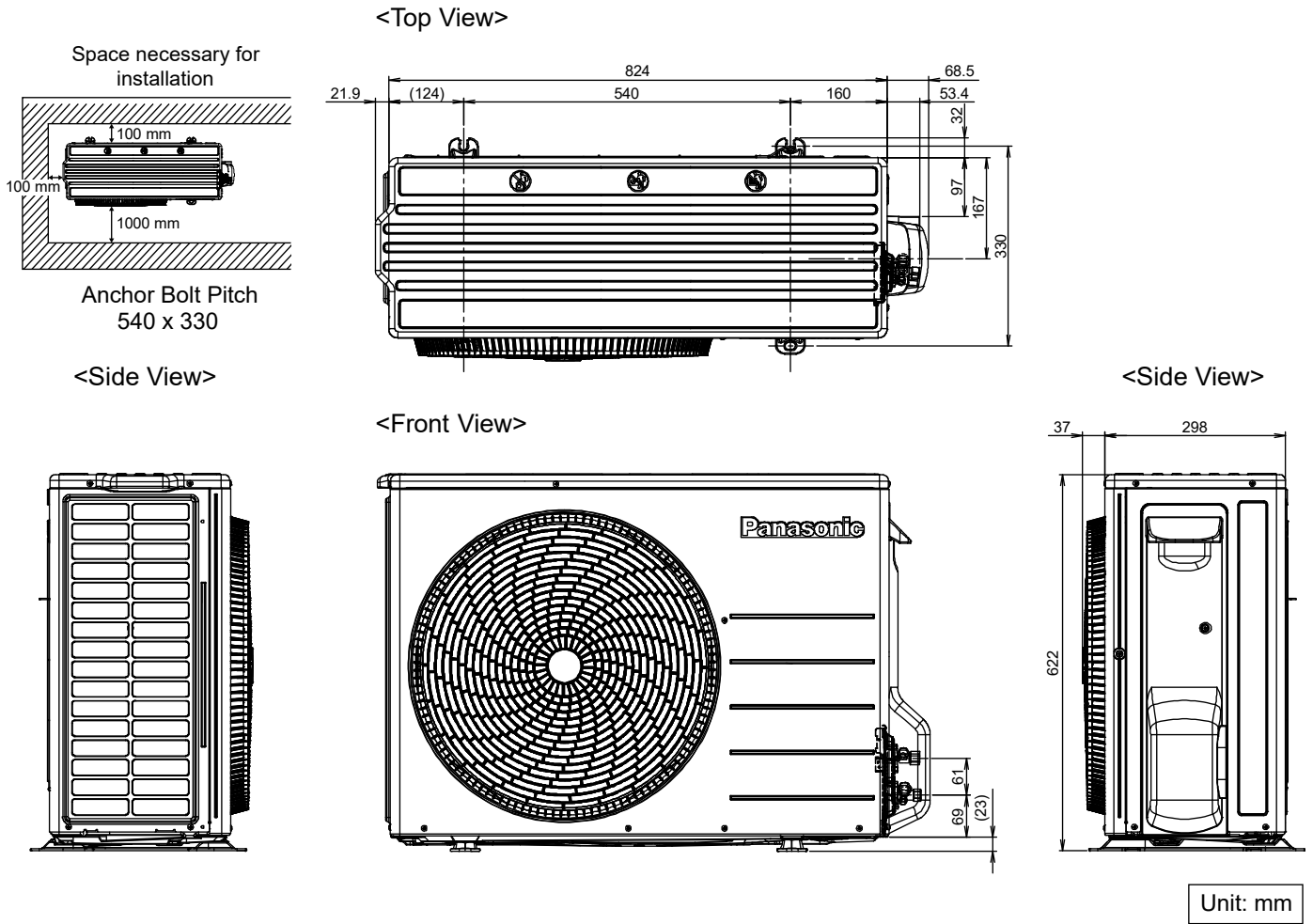

6.2.2 WH-UDZ05KE5 WH-UDZ07KE5 WH-UDZ09KE5

